



Mounting aid

MH 01-M18

- Suitable for M18 sensors
- Simple and fast mounting

Mounting brackets for sensors

Dimensions

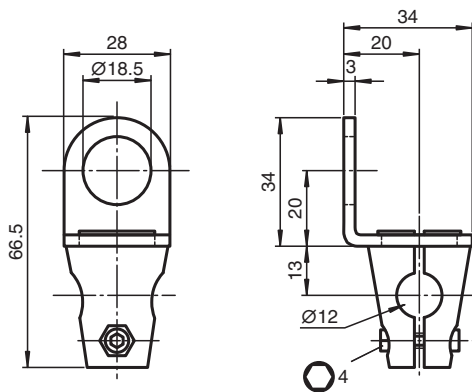

Technical Data

General specifications

Inside diameter 18 mm

Mechanical specifications

Material Clamping cylinder: Diecast zinc
Support bracket: Steel

Mounting

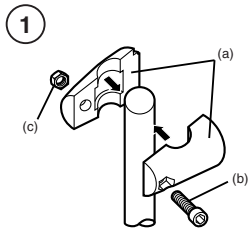

Fasten the two parts of the mounting clamp (a) loosely by means of the screw (b) and the nut (c) supplied.

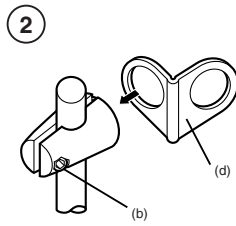

Attach the mounting bracket (d) and then tighten the screw (b) in such a way that the bracket can still be turned.

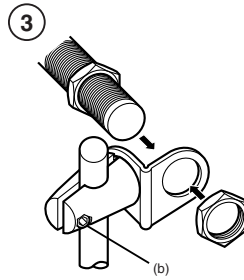

Tighten the screw fully after the sensor has been mounted and aligned.

Release date: 2020-06-15 Date of issue: 2020-06-29 Filename: 096532_eng.pdf